

"EVOLUTION LINE"

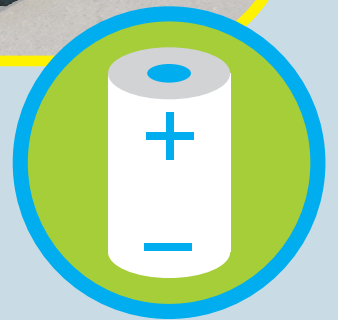

TCH-R16 FED

FULL ELECTRIC DUMPER

**MINITRACKED DUMPER
RAUPENTRANSPORTER**

Azienda certificata



GENERAL FEATURES

- Tracked Electric undercarriage with tilting rollers in the central area of the track and patented layout of track to ensure a wide footprint, high stability and excellent driving comfort in all conditions.
- Electric transmission powered by two inverters, two electric motors (designed for heavy duty work even in the toughest conditions) and two planetary gears.
- Drive control by two electronic joysticks with safety automatic reset to zero for stopping in warning conditions.
- Emergency button and electric brakes to ensure maximum operator safety.
- Hydraulic circuit for the skip lifting with electric motor pump controlled by dedicated inverter.

ALLEGEMEINE EIGENSCHAFTEN

- Höchster Fahrkomfort und höchste Stabilität in allen Situationen durch mittig angebrachte Gelenkrollenlager und patentiertem Kettenystem.
- Elektrischer Antrieb für Arbeiten unter härtesten Bedingungen durch optimale Auslegung der Wechselrichter, Fahrmotoren und Planetengetriebe.
- Ermüdungsfreies und sicheres Arbeiten durch elektronische Joystick-Steuerung mit automatischer Nullstellung im Warmmodus.
- Ein Notfallschalter sorgt für absolute Sicherheit.
- Der Elektromotor für den Hydraulikkreislauf der Mulde wird durch einen separaten Wechselrichter gesteuert.

TECHNICAL DATA

Operational weight with shovel (without operator)	kg	700
Max operating load	kg	1000
Vessel capacity: - heaped (SAE norms)	m ³	0.550
- struck by sand/struck by liquids	m ³	0.400 / 0.350
Skip capacity: - heaped (SAE norms)	m ³	0.500
- struck by sand/struck by liquids	m ³	0.370 / 0.320
Loading shovel capacity	l	65
Three-phase asynchronous electric motors with electronic control		
- Electric traction motors	n°	3 (2 + 1 for services)
- Nominal power (per motor)	kW/Hp	2 / 2.72
- Peak power	kW/Hp	4 / 5.44
- Maximum rotation speed	rpm	3000
- Rated voltage	V	80
- Maximum current offset	A	240
- Rated torque from 0 to 1500 rpm	daNm	4
Direct transmission on the gear motor		
- Maximum speed	km/h	5.7
- Maximum gradeint at full load	%	62
- Ground pressure: - empty / loaded	kg/cm ²	0.19 / 0.40
- Track width	mm	180
- Track tensioning		screw + spring
- Pump for services	type	gear pump
- Flow	l/min	5
- Maximum pressure for services	bar	170
- Battery capacity	kWh	8
- Number of elements	n°	25
- Chemical type of the cells		LiFePO4 (Lithium-Iron-Phosphate)
- Max working autonomy	h	3.5
- Average battery life (charge-discharge cycles)	n°	2000
- Recharging time with STD charger	h	4.5
- Recharging time with High Performance charger	h	1
- Cooling controller	type	air in forced convection
- Diagnostics and control electronic system	type	OpenCan

TECHNISCHE DATEN

Eigengewicht mit Ladeschaufel	kg	700
Nutzlast	kg	1000
Mulden Volumen: - gehäuft (SAE Norm)	m ³	0.550
- gestrichen (Flüssigkeit)	m ³	0.400 / 0.350
Schüttmulden Volumen: - gehäuft (SAE Norm)	m ³	0.500
- gestrichen (Flüssigkeit)	m ³	0.370 / 0.320
Ladeschaufel Volumen	l	65
Drei Phasen asynchron Elektromotoren Elektronisch gesteuert		
- Anzahl der Elektromotoren	stck.	2 + 1
- Nominale Leistung je Motor	kW/PS	2 / 2.72
- Leistung in der Spitze	kW/PS	4 / 5.44
- Max. U/min	U/min	3000
- Nenn-Spannung	V	80
- Stomstärke max.	A	240
- Nenn-Drehmoment von 0-1.500 U/min	daNm	4
- Fahrgeschwindigkeit max.	Km/h	5.7
- Steigfähigkeit max. voll beladen	%	62
- Bodendruck leer/beladen	kg/cm ²	0.19 / 0.40
- Breite der Raupenkette	mm	180
- Raupenkettenspannung		Feder und Schraube
- Pumpen	typ	Zahnradpumpen
- Durchfluss	l/min	5
- Betriebsdruck max	bar	170
- Batterie kapazität	kWh	8
- Anzahl der Elemente	stck.	25
- Typ der Zellen		LiFePO4 (Lithium-Eisenphosphat)
- Reichweite je Akkuladung	h	3,5
- Lebensdauer der Akkus (Ladezyklen)	stck.	2000
- Ladezeit der Akkus (Standardladegerät)	h	4.5
- Ladezeit der Akkus (Schnellladegerät)	h	1
- Kühlung der Steuereinheit	typ	Luftkühlung
- Diagnose- und Kontrollsystem	typ	CAN

OVERALL DIMENSIONS / ABMESSUNGEN

Dimensions in mm / Maße in mm

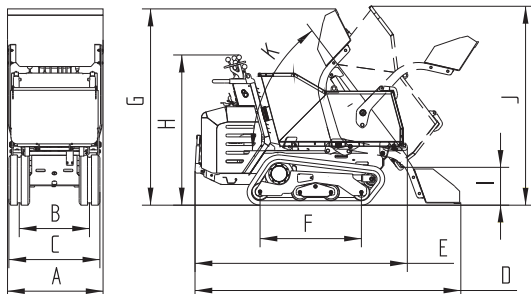

	A	B	C	D	E	F	G	H	I	J	K
TCH-R16 FED	830	610	790	2308	1843	880	1699	1304	328	1727	53°

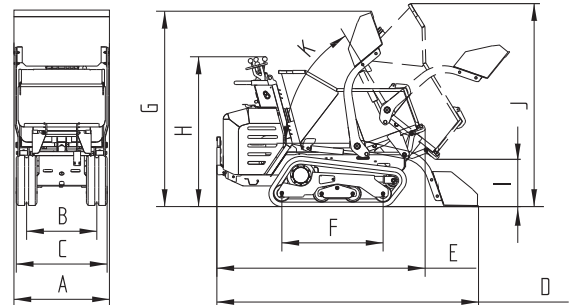

	A	B	C	D	E	F	G	H	I	J	K
TCH-R16 FED	830	610	790	2275	1809	880	1699	1304	476	1763	59°

Via Arcevese, 44
60010 CASINE di OSTRÀ (AN) Italy
Tel.071.688771 r.a. - Fax 071.688586
Web: www.messersi.it
E-mail: messersi@messersi.it

Data, features and pictures are not binding and may be altered without any prior notice.
Änderungen ohne Ankündigung vorbehalten, Angaben ohne Gewähr.

